

## JLG® Ultra Series. Performance Unleashed.

Steel mills and chemical plants, airports, convention centers, shipyards and heavy construction. JLG® Ultra Series boom lifts are designed for rugged job sites that demand you work higher and reach farther. With four decades of experience, JLG knows the territory. You need the power, reliability and versatility to do the impossible every day. And, come back and do it again tomorrow.

JLG Ultra Series boom lifts get you there. They're built from 100,000 psi steel—40% stronger than the competition, and they'll lift 1,000 pounds to 135 feet, making them the most powerful booms in the industry.

When you're working ten stories high, you want a machine that gives you confidence to do your best work; that's built to perform and that's designed to meet any challenge. To have the most productive day possible, you want the power of orange. The power of JLG.



## Putting Your Work Above Everything.

When it comes to JLG® Ground Support, it's all about you. Your productivity. Your profitability. Your uptime. From the purchase of your first piece of equipment straight through to the training, parts and maintenance that follows.



### Customer Service Call Center

You can be assured we'll be giving an all-out effort to support you. Just think of us as your personal on-call, full-service support team. We make it happen. Period.



### Financial Solutions

Maximizing your profits. Preserving your cash flow. Let our financing specialists help choose the program designed specifically for your needs.



### Aftermarket Parts

Keep your equipment running at peak performance with genuine replacement parts, accessories, attachments, rebuilt and competitive parts all from one source—JLG.



### Training

Knowing your equipment inside and out results in higher productivity on the job. Our instructor-led courses give you the hands-on time you need for success.



### Service Centers

Your needs. Your uptime. JLG is on the job to fulfill your every need, from repair, reconditioning, same-day parts and much more. We're here to support you.

### 1250AJP

#### Ultra Series Articulating Boom Lifts

##### Reach Specifications

Platform Height	125 ft (38.1 m)
Horizontal Reach	63 ft 2 in. (19.25 m)
Up and Over Height	60 ft 6 in. (18.44 m)
Swing	360° Continuous
Platform Capacity—Restricted	1,000 lb (454 kg)
Platform Capacity—Unrestricted	500 lb (227 kg)
Platform Rotator	180°
JibPLUS®	
Length	8 ft (2.44 m)
Horizontal Motion <sup>1</sup>	125°
Vertical Motion	130° (+75/-55)

##### Dimensional Data

A. Platform Size	36 x 96 in. (0.91 x 2.44 m)
B. Overall Width	Axles Retracted 8 ft 2 in. (2.49 m)
	Overall Width Axles Extended 12 ft 6 in. (3.81 m)
C. Tailswing	3 ft (91 cm)
D. Stowed Height	10 ft (3.05 m)
E. Stowed Length	37 ft 7 in. (11.45 m)
F. Wheel Base	12 ft 6 in. (3.81 m)
Ground Clearance	Axle 12 in. (30 cm)
	Chassis 25.5 in. (65 cm)
Weight <sup>2</sup>	44,000 lb (19,958 kg)

##### Chassis

Max Ground Bearing Pressure*	100 psi (7.03 kg/cm <sup>2</sup> )
Drive Speed	3.25 mph (5.2 mph)
Gradeability	45%
Turning Radius (Inside)	Axles Retracted 14 ft 5 in. (4.39 m)
	Axles Extended 8 ft (2.44 m)
Turning Radius (Outside)	Axles Retracted 22 ft 6 in. (6.86 m)
	Axles Extended 19 ft 4 in. (5.89 m)
Crab Steer Ratio <sup>3</sup>	1:1
Axle Oscillation	12 in. (30 cm)
Tires/Type	445/50D710 Foam Filled

##### Power Source

Diesel Engine	Deutz BF4M 2011	87 hp (65 kW)
Fuel Tank Capacity		31 gal (117 L)
Hydraulic Reservoir		55 gal (208 L)
Auxiliary Power		12V DC
Generator Nominal/Continuous		12,000/7,500 Watt

- \* Ground bearing pressure applies to standard tires.
- 1. Capacity is limited to 500 lb (227 kg) when JibPLUS is extended horizontally.
- 2. Certain options or country standards increase weight.
- 3. Ratio of forward travel to lateral travel.

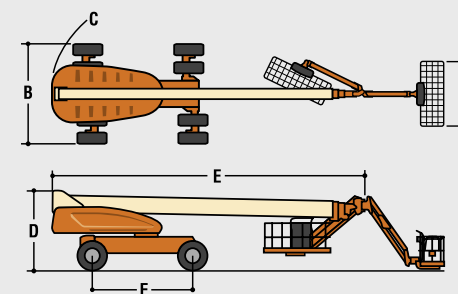

##### Standard Features

- Platform: 36 x 96 in. (0.91 x 2.44 m) Side Entry
- 8 ft (2.44 m) JibPLUS® Boom
- Selectable Capacity Envelope
- Inward Swinging Gate
- 180° Hydraulic Platform Rotator
- AC Receptacle in the Platform
- SkyPower® Package
  - 7500 Watt Generator
  - 240/120V Single Phase
  - 240V 3 Phase
- 1/2 in. Air Line to Platform
- 5 Degree Tilt Alarm/Indicator Light
- All Motion Alarm
- Swing-Out Engine Tray
- 12V DC Auxiliary Power
- Hourmeter
- Control ADE® System
- Full-time 4WD
- 3 Selectable Steering Modes
- Drive-out Extendible Axles
- Oscillating Axle
- Proportional Controls
- Gull-Wing Hoods
- Operator Tool Tray
- 445/50D710 Foam Filled Rim Protector Lug Tread Tires
- Platform Console Machine Status Light Panel\*
- Lifting/Tie Down Lugs
- Engine Distress
- Warning/Shutdown—Selectable via JLG Analyzer

##### Available Options

- Platform: 36 x 72 in.
- Fall-Arrest Platform: 36 x 96 in. (0.91 x 1.83 m) Side Entry
- Light Package<sup>1</sup>
- Flashing Beacon
- Soft-Touch System Platform
- 6 ft/8 ft (1.83 m/2.44 m)
- Catalytic Muffler
- Cold Weather Start<sup>2</sup>
- Hostile Environment Kit<sup>3</sup>
- Mesh to Top Rail

1. Includes platform mounted work lights and drive/backup lights.
2. Includes glow plugs, battery heater and oil tank heater.
3. Includes console cover, boom wipers and cylinder bellows.

##### Accessory Packages

- SkyWelder®
  - SkyCutter®
  - SkyGlazier®
  - Nite Bright®
  - Pipe Racks
- \* Provides indicator lights at platform control console for system distress, fuel level, low fuel, 5 degree tilt light and foot switch status.

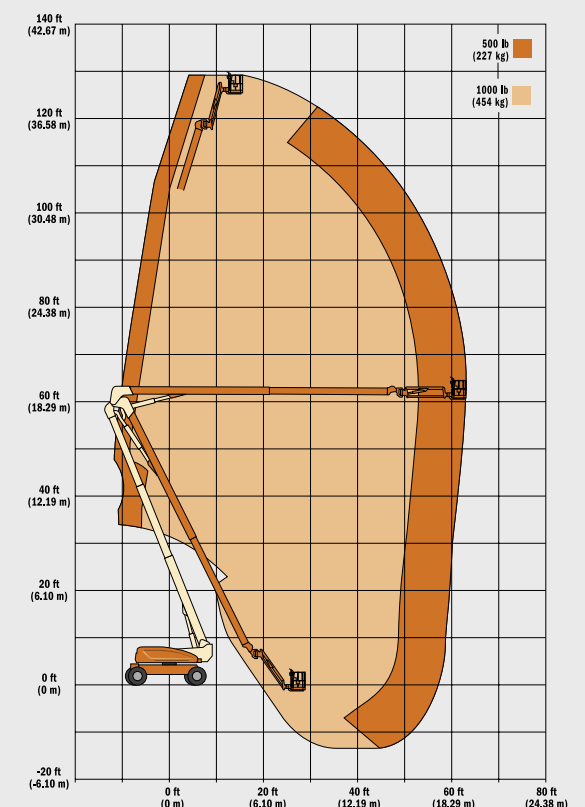

For complete specifications, visit [www.jlg.com](http://www.jlg.com)

# ULTRA SERIES TELESCOPIC BOOM LIFTS

## SPECIFICATIONS

1200SJP	
<b>Ultra Series Telescopic Boom Lifts</b>	
<b>Reach Specifications</b>	
Platform Height	120 ft (36.58 m)
Horizontal Reach	75 ft (22.86 m)
Up and Over Height	—
Swing	360° Continuous
Platform Capacity—Restricted	1,000 lb (454 kg)
Platform Capacity—Unrestricted	500 lb (227 kg)
Platform Rotator	180°
JibPLUS®	
Length	8 ft (2.44 m)
Horizontal Motion <sup>1</sup>	180°
Vertical Motion	130° (+75/-55)

Dimensional Data	
A. Platform Size	36 x 96 in. (0.91 x 2.44 m)
B. Overall Width	Axles Retracted 8 ft 2 in. (2.49 m)
Overall Width	Axles Extended 12 ft 6 in. (3.81 m)
C. Tailswing	5 ft 6 in. (1.67 m)
D. Stowed Height	10 ft (3.05 m)
E. Stowed Length	34 ft 11 in. (10.64 m)
F. Wheel Base	12 ft 6 in. (3.81 m)
Ground Clearance	Axle 12 in. (30 cm)
Chassis	25.5 in. (65 cm)
Weight <sup>2</sup>	40,900 lb (18,552 kg)

Chassis	
Max Ground Bearing Pressure*	100 psi (7.03 kg/cm <sup>2</sup> )
Drive Speed	3.25 mph (5.2 mph)
Gradeability	45%
Turning Radius (Inside)	Axles Retracted 14 ft 5 in. (4.39 m)
Axles Extended	8 ft (2.44 m)
Turning Radius (Outside)	Axles Retracted 22 ft 6 in. (6.86 m)
Axles Extended	19 ft 4 in. (5.89 m)
Crab Steer Ratio <sup>3</sup>	1:1
Axle Oscillation	12 in. (30 cm)
Tires/Type	445/50D710 Foam Filled

Power Source	
Diesel Engine	Deutz BF4M 2011 87 hp (65 kW)
Fuel Tank Capacity	31 gal (117 L)
Hydraulic Reservoir	55 gal (208 L)
Auxiliary Power	12V DC
Generator	7500 Watt

- \* Ground bearing pressure applies to standard tires.  
 1. Capacity is limited to 500 lb (227 kg) when JibPLUS is extended horizontally.  
 2. Certain options or country standards increase weight.  
 3. Ratio of forward travel to lateral travel.

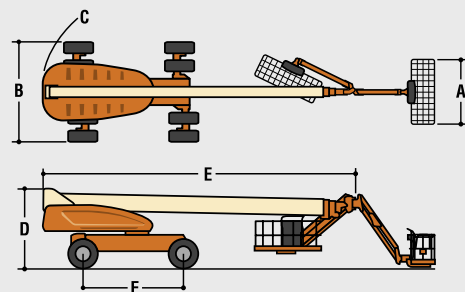

Standard Features	
Platform: 36 x 96 in. (0.91 x 2.44 m) Side Entry	
8 ft (2.44 m) JibPLUS® Boom	
Selectable Capacity Envelope	
Inward Swinging Gate	
180° Hydraulic Platform Rotator	
AC Receptacle in the Platform	
SkyPower® Package	
7500 Watt Generator	
• 240/120V Single Phase	
• 240V 3 Phase	
1/2 in. Air Line to Platform	

5 Degree Tilt Alarm/Indicator Light
All Motion Alarm
Swing-Out Engine Tray
12V DC Auxiliary Power
Hourmeter
Control ADE® System
Full-time 4WD
3 Selectable Steering Modes
Drive-out Extendible Axles
Oscillating Axle
Proportional Controls
Gull-Wing Hoods
Operator Tool Tray
445/50D710 Foam Filled Rim Protector Lug Tread Tires
Platform Console Machine Status Light Panel*
Lifting/Tie Down Lugs
Engine Distress
Warning/Shutdown—Selectable via JLG Analyzer

Available Options	
Platform: 36 x 72 in. (0.91 x 1.83 m) Side Entry	
Light Package <sup>1</sup>	
Flashing Beacon	
Soft-Touch System Platform	
6 ft/8 ft (1.83 m/2.44 m)	
Catalytic Muffler	
Cold Weather Start <sup>2</sup>	
Hostile Environment Kit <sup>3</sup>	
Mesh to Top Rail	

- Includes platform mounted work lights and drive/backup lights.
- Includes glow plugs, battery heater and oil tank heater.
- Includes console cover, boom wipers and cylinder bellows.

### Accessory Packages

SkyWelder®
SkyCutter®
SkyAir® (1200/1350SJP only)
SkyGlazier®
Nite Bright®
Pipe Racks

\* Provides indicator lights at platform control console for system distress, fuel level, low fuel, 5 degree tilt light and foot switch status.

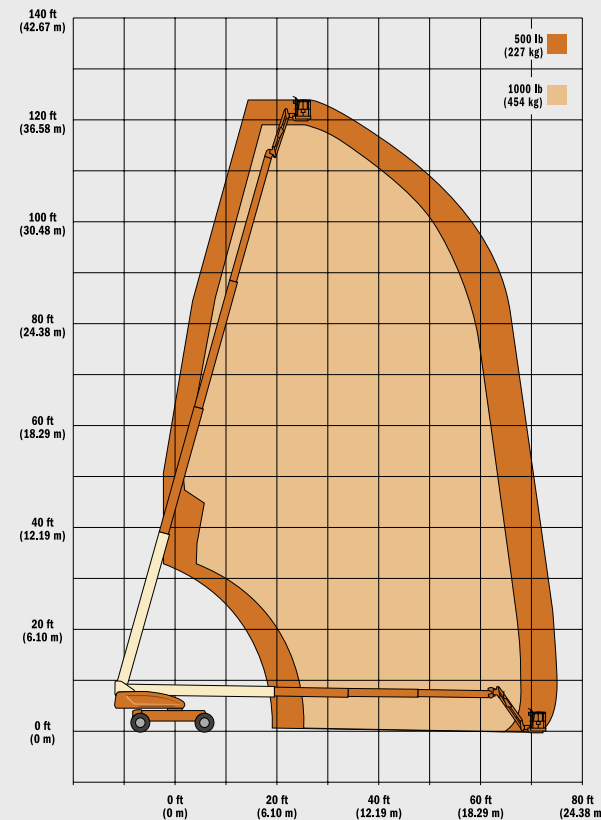

1350SJP	
<b>Ultra Series Telescopic Boom Lifts</b>	
<b>Reach Specifications</b>	
Platform Height	135 ft (41.15 m)
Horizontal Reach	63 ft 2 in. (19.25 m)
Up and Over Height	—
Swing	360° Continuous
Platform Capacity—Restricted	1,000 lb (454 kg)
Platform Capacity—Unrestricted	500 lb (227 kg)
Platform Rotator	180°
JibPLUS®	
Length	8 ft (2.44 m)
Horizontal Motion <sup>1</sup>	180°
Vertical Motion	130° (+75/-55)

Dimensional Data	
A. Platform Size	36 x 96 in. (0.91 x 2.44 m)
B. Overall Width	Axles Retracted 8 ft 2 in. (2.49 m)
Overall Width	Axles Extended 12 ft 6 in. (3.81 m)
C. Tailswing	5 ft 6 in. (1.67 m)
D. Stowed Height	10 ft (3.05 m)
E. Stowed Length	38 ft 11 in. (11.86 m)
F. Wheel Base	12 ft 6 in. (3.81 m)
Ground Clearance	Axle 12 in. (30 cm)
Chassis	25.5 in. (65 cm)
Weight <sup>2</sup>	45,000 lb (20,411 kg)

Chassis	
Max Ground Bearing Pressure*	105 psi (7.38 kg/cm <sup>2</sup> )
Drive Speed	3.25 mph (5.2 mph)
Gradeability	45%
Turning Radius (Inside)	Axles Retracted 14 ft 5 in. (4.39 m)
Axles Extended	8 ft (2.44 m)
Turning Radius (Outside)	Axles Retracted 22 ft 6 in. (6.86 m)
Axles Extended	19 ft 4 in. (5.89 m)
Crab Steer Ratio <sup>3</sup>	1:1
Axle Oscillation	12 in. (30 cm)
Tires/Type	445/50D710 Foam Filled

Power Source	
Diesel Engine	Deutz BF4M 2011 87 hp (65 kW)
Fuel Tank Capacity	31 gal (117 L)
Hydraulic Reservoir	55 gal (208 L)
Auxiliary Power	12V DC
Generator Nominal/Continuous	12,000/7,500 Watt

- \* Ground bearing pressure applies to standard tires.  
 1. Capacity is limited to 500 lb (227 kg) when JibPLUS is extended horizontally.  
 2. Certain options or country standards increase weight.  
 3. Ratio of forward travel to lateral travel.

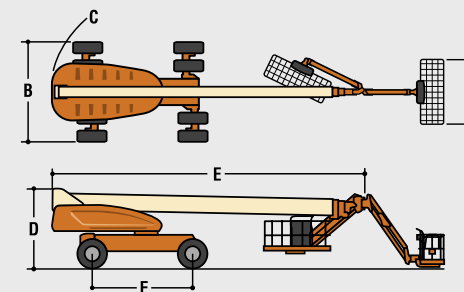

# ULTRA SERIES TELESCOPIC BOOM LIFTS

## SPECIFICATIONS

Standard Features	
Platform: 36 x 96 in. (0.91 x 2.44 m) Side Entry	
8 ft (2.44 m) JibPLUS® Boom	
Selectable Capacity Envelope	
Inward Swinging Gate	
180° Hydraulic Platform Rotator	
AC Receptacle in the Platform	
SkyPower® Package	
7500 Watt Generator	
• 240/120V Single Phase	
• 240V 3 Phase	
1/2 in. Air Line to Platform	

5 Degree Tilt Alarm/Indicator Light
All Motion Alarm
Swing-Out Engine Tray
12V DC Auxiliary Power
Hourmeter
Control ADE® System
Full-time 4WD
3 Selectable Steering Modes
Drive-out Extendible Axles
Oscillating Axle
Proportional Controls
Gull-Wing Hoods
Operator Tool Tray
445/50D710 Foam Filled Rim Protector Lug Tread Tires
Platform Console Machine Status Light Panel*
Lifting/Tie Down Lugs
Engine Distress
Warning/Shutdown—Selectable via JLG Analyzer

Available Options	
Platform: 36 x 72 in. Fall-Arrest Platform: 36 x 96 in. (0.91 x 1.83 m) Side Entry	
Light Package <sup>1</sup>	
Flashing Beacon	
Soft-Touch System Platform	
6 ft/8 ft (1.83 m/2.44 m)	
Catalytic Muffler	
Cold Weather Start <sup>2</sup>	
Hostile Environment Kit <sup>3</sup>	
Mesh to Top Rail	

- Includes platform mounted work lights and drive/backup lights.
- Includes glow plugs, battery heater and oil tank heater.
- Includes console cover, boom wipers and cylinder bellows.

### Accessory Packages

SkyWelder®
SkyCutter®
SkyAir® (1200/1350SJP only)
SkyGlazier®
Nite Bright®
Pipe Racks

\* Provides indicator lights at platform control console for system distress, fuel level, low fuel, 5 degree tilt light and foot switch status.

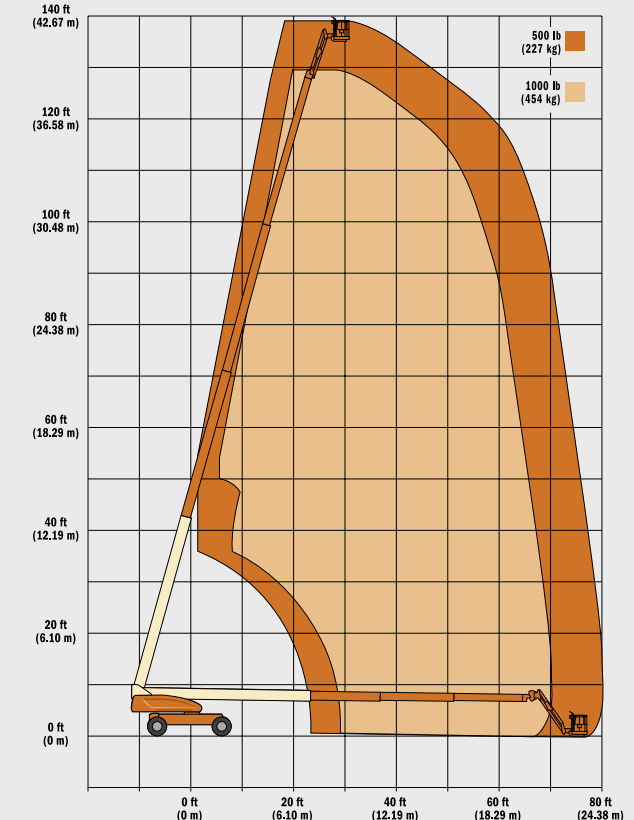

# TELESCOPIC BOOM LIFTS

	<b>1200SJP</b>	<b>1350SJP</b>
Platform Height	36.58 m	41.15 m
Horizontal Outreach	22.86 m	24.38 m
Swing (Continuous)	360°	360°
Platform Capacity – Restricted	450 kg	450 kg
Platform Capacity – Unrestricted	230 kg	230 kg
Platform Rotator (Hydraulic)	180°	180°
Jib – Overall Length	2.44 m	2.44 m
Jib - Range of articulation	130° Vertical (+75°/-55°)	130° Vertical (+75°/-55°)
JibPLUS™ - Range of Articulation	180° Horizontal	180° Horizontal
A. Platform Size	0.91 m x 2.44 m	0.91 m x 2.44 m
B. Overall Width (Axles Retracted)	2.49 m	2.49 m
Overall Width (Axles Extended)	3.80 m	3.80 m
C. Tailswing (working condition)	1.67 m	1.67 m
D. Stowed Height	3.05 m	3.05 m
E. Stowed Length	10.64 m	11.86 m
F. Wheelbase	3.81 m	3.81 m
Ground Clearance	0.30 m	0.30 m
Gross Vehicle Weight <sup>1</sup>	18,650 kg	20,300 kg
Maximum Ground Bearing Pressure	7.03 kg/cm <sup>2</sup>	7.38 kg/cm <sup>2</sup>
Drive Speed	5.2 km/h	5.2 km/h
Gradeability	45%	45%
Tyres	445/50D710 Foam Filled	445/50D710 Foam Filled
Axle Oscillation	0.30 m	0.30 m
Turning Radius – Inside (Axles Retracted)	4.39 m	4.39 m
Turning Radius – Inside (Axles Extended)	2.44 m	2.44 m
Turning Radius – Outside (Axles Retracted)	6.86 m	6.86 m
Turning Radius – Outside (Axles Extended)	5.89 m	5.89 m
Diesel Engine - Deutz BF 4M 2011	65 kW	65 kW
Fuel Tank Capacity	117 L	117 L
Hydraulic Reservoir	208 L	208 L
Auxiliary Power	12V DC	12V DC

<sup>1</sup> Certain options or country standards will increase weight.

Specifications may change to meet country standards or with the addition of optional equipment.



# JLG MODEL 1200SJP

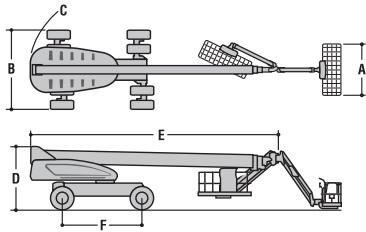
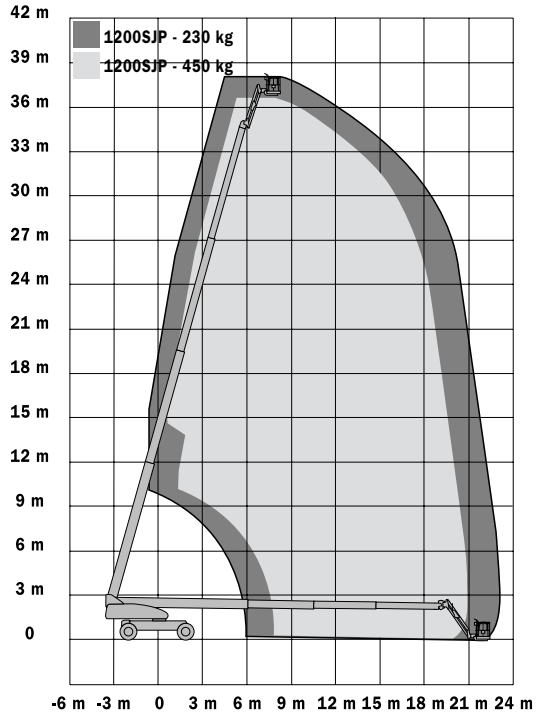

# JLG MODEL 1350SJP

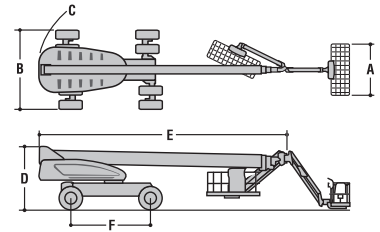
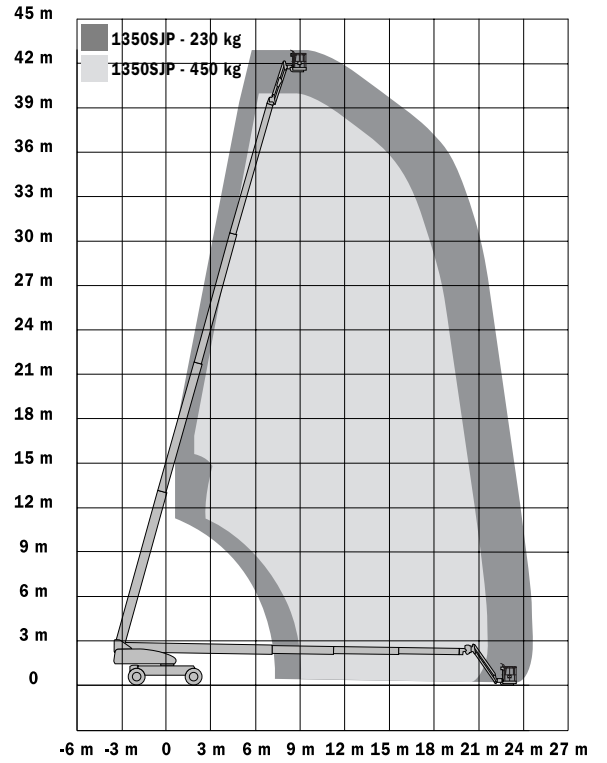

# ARTICULATING BOOM LIFTS

## 1250AJP

Platform Height	38.10 m
Horizontal Outreach	19.25 m
Up and Over Height	18.44 m
Swing (Continuous)	360°
Platform Capacity – Restricted	450 kg
Platform Capacity – Unrestricted	230 kg
Platform Rotator (Hydraulic)	180°
Jib – Overall Length	2.44 m
Jib - Range of articulation	130° Vertical (+75°/-55°)
JibPLUS® - Range of Articulation	125° Horizontal
A. Platform Size	0.91 m x 2.44 m
B. Overall Width (Axles Retracted)	2.49 m
Overall Width (Axles Extended)	3.81 m
C. Tailswing (working condition)	2.26 m
D. Stowed Height	3.05 m
E. Stowed Length	11.46 m
F. Wheelbase	3.81 m
G. Ground Clearance	0.30 m
Gross Vehicle Weight*	19,958 kg
Maximum Ground Bearing Pressure	7.03 kg/cm <sup>2</sup>
Drive Speed	5.2 km/h
Gradeability	45%
Tyres	445/50D710 Foam Filled
Axle Oscillation	0.30 m
Turning Radius – Inside (Axles Retracted)	4.39 m
Turning Radius – Inside (Axles Extended)	2.44 m
Turning Radius – Outside (Axles Retracted)	6.86 m
Turning Radius – Outside (Axles Extended)	5.89 m
Diesel Engine - Deutz BF 4M 2011	65 kW
Fuel Tank Capacity	117 L
Hydraulic Reservoir	202 L
Auxiliary Power	12V DC

\*Certain options or country standards will increase weight.  
Specifications may change to meet country standards or with the addition of optional equipment.



# JLG MODEL 1250AJP

